



SOFATH®
Le Chauffage Nature

Natea
de SOFATH

TECHNOLOGY

Direct evaporation

Direct condensation



Technical documentation – V 1.0

June 2006

THERMATIS Technologies

Headquarter and factory : B.P. 100 - Z.I. Morlon - 26802 Portes-lès-Valence Cedex Tel.:+33 (0)4 75 57 30 30 - Fax :+33 (0)4 75 57 24 00
1 000 000 Euros registered Romans : B 408 193 639 - Code APE 292 F - <http://www.sofath.com> - E-mail : sofath@sofath.com

SOFATH® is a brand name of THERMATIS Technologies



Summary

INTRODUCTION	3
1 SCHEMATIC DIAGRAM OF HEATING	ERREUR ! SIGNET NON DEFINI.
2 EFFICIENT USE OF ENERGY	ERREUR ! SIGNET NON DEFINI.
DESCRIPTION	4
1 THE GEOTHERMAL GROUND COLLECTOR	ERREUR ! SIGNET NON DEFINI.
2 THE HEAT PUMP	5
3 HOUSING SIZES	6
4 THE UNDER FLOOR HEATING	6
5 TEMPERATURE REGULATION	7
6 DOMESTIC HOT WATER (OPTION)	ERREUR ! SIGNET NON DEFINI.
7 REGULATION OF HEATING ZONES	9
8 SWIMMINGPOOL (OPTION)	9
9 COOLING (OPTION)	9
SCHEMATICAL DIAGRAM	ERREUR ! SIGNET NON DEFINI.

INTRODUCTION

The *Natea* R410A range is a range of heat pumps with buried loops, using the DX technology.

1 SCHEMATIC DIAGRAM FOR HEATING

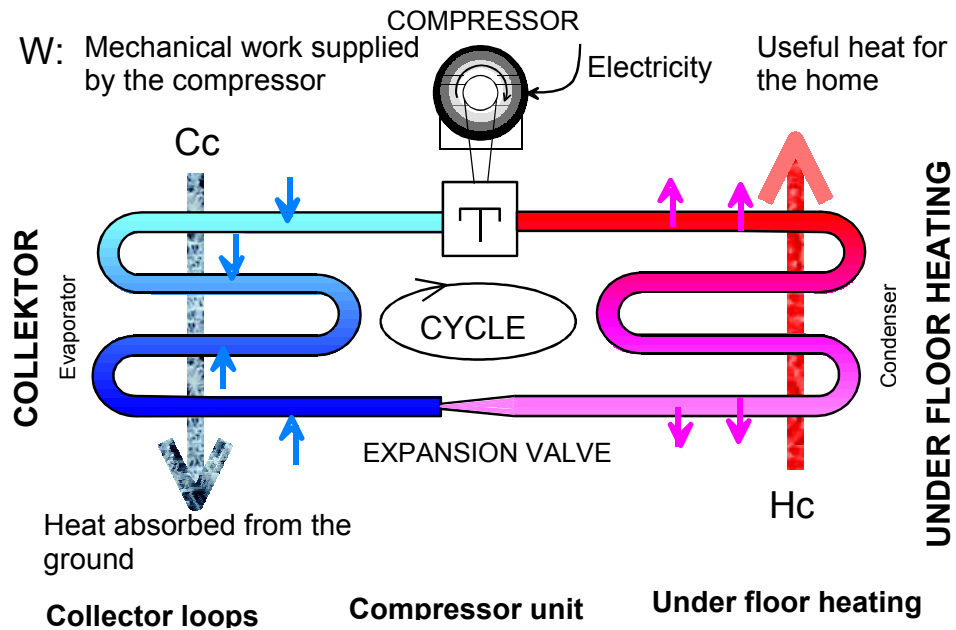

2 EFFICIENT USE OF ENERGY

The entire *Natea* R410a range is designed to allow the most efficient use of energy for the heating and cooling of buildings.

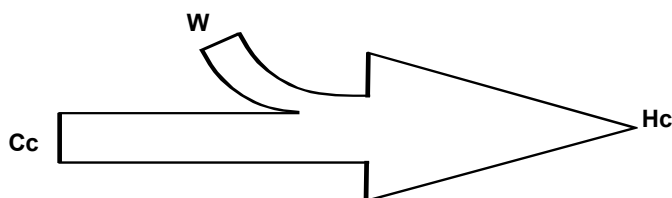

Useful heat for the home results from the amount of heat absorbed from the ground and the mechanical work supplied by the compressor (ideally equivalent to its electrical consumption).

Thus, 1 kW of electricity consumed is converted up to 4 kW or more of useful heat for the home.



DESCRIPTION

The *Natea* R410A range consists of three main elements:

- the geothermal ground collector
- the compressor unit
- the under floor heating

1 GEOTHERMAL GROUND COLLECTOR

The collector's role is to absorb the heat stored in the ground and transfer it, at the highest possible temperature, into the home via a heat pump.

This consists of a series of loops which are distributed across an even depth, generally between 0.6 and 1.0 m beneath the ground.

The collector- loops are made from copper tubing suitable for carrying refrigerant and they are coated with green polyethylene. When leaving the factory they are nitrogen pressurized.

Available standard lengths:

- 95 m for heat pump type MT2.10
- 75 m for all the other models.

	MT2.10	MT4.10	MT5.10	MT7.10	MT9.10	MT11.10
N° of collector-loops	1	2	3	4	5	6

➤ **Tube diameter : 3/8" or 9.52 mm.**



Distributor
Out to collector



Distributor
Back from collector



2 THE HEAT PUMP

Nominal values

	MT2.10	MT4.10	MT5.10	MT7.10	MT9.10	MT11.10
Number of collector loops	1	2	3	4	5	6
Number of under floor coils	1	2 - 3	3 - 4	4 - 5	5 - 6	6 - 7
Total length	70 - 110	100 - 220	180 - 330	200 - 440	270 - 550	300 - 660
Heating capacity (W)	2300	3950	5500	7150	9500	11300
Refrigerant	R410A					
Electrical supply	230V~ 50Hz	230V~50Hz 400V3N~ 50Hz	230V~50Hz 400V3N~ 50Hz	230V~50Hz 400V3N~ 50Hz	230V~50Hz 400V3N~ 50Hz	400V3N~ 50Hz
Amp rating (A) ⁽²⁾	4	6,5 2,5	9,4 2,5	12 4,4	19.2 5,8	6,5
Maximum current	6	10 3,1	14 4,1	17 5,7	23 7,7	8,4
Starting current (A) ⁽³⁾	24	58 26	82 35	97 48	150 64	74
Connection out to Under floor heating	3/8"	3/8"	1/2"	1/2"	5/8"	5/8"
Connection back from Under floor	3/8"	3/8"	3/8"	3/8"	1/2"	1/2"
Connection out to ground collector	3/8"	3/8"	1/2"	1/2"	5/8"	3/4"
Connection back from ground collector	3/8"	3/8"	1/2"	5/8"	5/8"	3/4"
Domestic hot water	-	-	○	○	○	○
Cooling ⁽¹⁾	-	○	○	○	○	○
Pool water heating ⁽¹⁾	-	-	○	○	○	○

(1) : Cooling and pool water options cannot be combined (2) + (3) compressor value ○ : available option

For heat pump selection take nominal values only

Calculated heating capacities for 3 different evaporation temperatures

	MT2.10	MT4.10	MT5.10	MT7.10	MT9.10	MT11.10
0°C/35°C (*)						
Heating capacity (W)	3340	5650	7850	10250	13620	16840
Power input (W)	830	1320	1730	2200	2860	3340
-5°C/35°C (*)						
Heating capacity (W)	2850	4700	6500	8540	11340	14200
Power input (W)	850	1340	1780	2250	2800	3340
-10°C/35°C (*)						
Heating capacity (W)	2460	3950	5500	7150	9500	11850
Power input (W)	840	1350	1830	2310	2800	3330

(*) Evaporation temperature / Condensation temperature. Calculations based on compressor supplier values



3 HOUSING SIZES



	AG 100	AG 200	AG 300
Depth (m)	0.74	0.74	0.74
Height (m)	0.71	1.30	1.90
Width (m)	0.67	0.67	0.67

4 THE UNDER FLOOR HEATING

The under floor heating transmits to the home the heat absorbed from the ground and a part of the energy consumed by the compressor unit.

The floor coils are made of copper tubing suitable for carrying refrigerant, and they are coated with red polyethylene.

The characteristics of the under floor heating vary according to the compressor model:

	MT2.10	MT4.10	MT5.10	MT7.10	MT9.10	MT11.10
Minimum length to respect (m)	70	100	180	200	270	300
Maximum length (m)	110	220	330	440	550	660
Number of under floor coils	1	2-3	3-4	4-5	5-6	6-7

- *Minimum number of coils*
- *Tube diameter: 3/8" or 9.52 mm.*
- *Length of under floor coils: 110 m.*

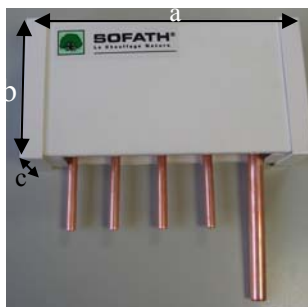

	2 Connections	4 Connections	6 Connections
a (mm)	210	320	430
b (mm)	110	110	110
c (mm)	40	40	40

Under floor heating manifold
Available with 2, 4 and 6 connections



5 TEMPERATURE REGULATION

The entire *Natea* -R410A range can be regulated by one or several room thermostat (s).

These thermostats are available as mechanical, electronic with visual display unit or electronic with visual display and weekly programming option....

Regulation Comfort:

- Room thermostat (mechanical)
- Zone regulation (pilot and setback)
- Can be used for cooling
- heating mode 2 –wires-, cooling mode 3 – wires connection



Regulation Comfort Digital:

- Electronic thermostat with digital visual display
- Zone regulation (pilot and setback)
- One touch for temperature lowering
- Can be used for cooling
- Voltage 230V
- Heating mode 4 – wires-, cooling mode 5 – wires connection



Regulation Comfort Programmable:

- Electronic thermostat with digital visual display and
- Weekly programming
- Zone regulation (advised for pilot zones)
- Can be used for cooling
- Voltage 230V
- Heating mode 4 – wires-, cooling mode 5 – wires connection





6 – DOMESTIC HOT WATER (optional)

The geothermal SOFATH water heater can be installed on the entire range from the MT5.10 up to the MT11.10.

When the heat pump is operating, it produces all domestic hot water with the hot gas coming out of the compressor. The hot water temperature will be about 65°C.

In the summer, domestic hot water is produced automatically by the electrical resistance connected at the “off-peak” tariff.

Water heater:

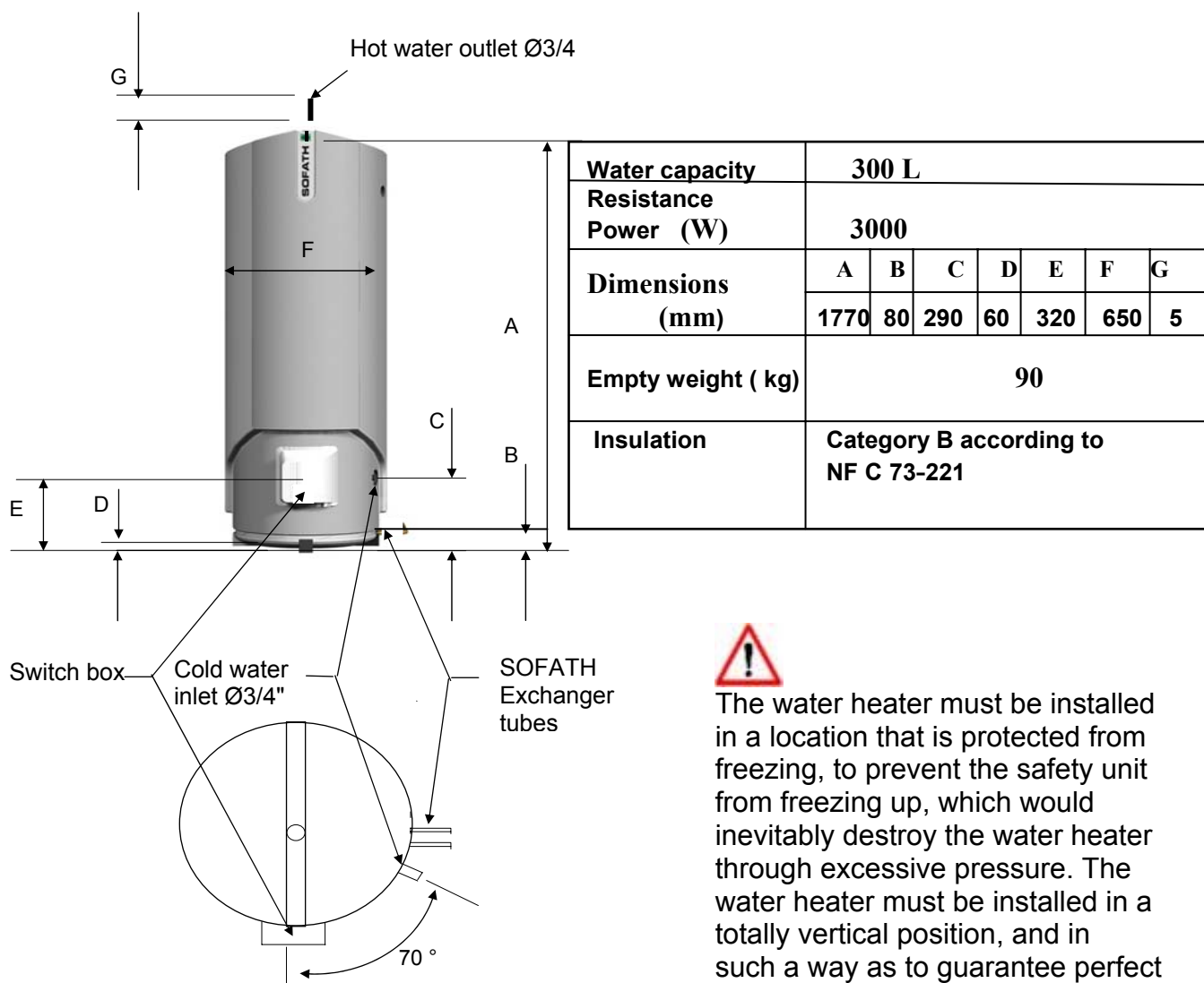

The water heater must be installed in a location that is protected from freezing, to prevent the safety unit from freezing up, which would inevitably destroy the water heater through excessive pressure. The water heater must be installed in a totally vertical position, and in such a way as to guarantee perfect stability.

The hydraulic connection must be performed in accordance with current regulations.

**SOFATH®**
Le Chauffage Nature

● Domestic hot water

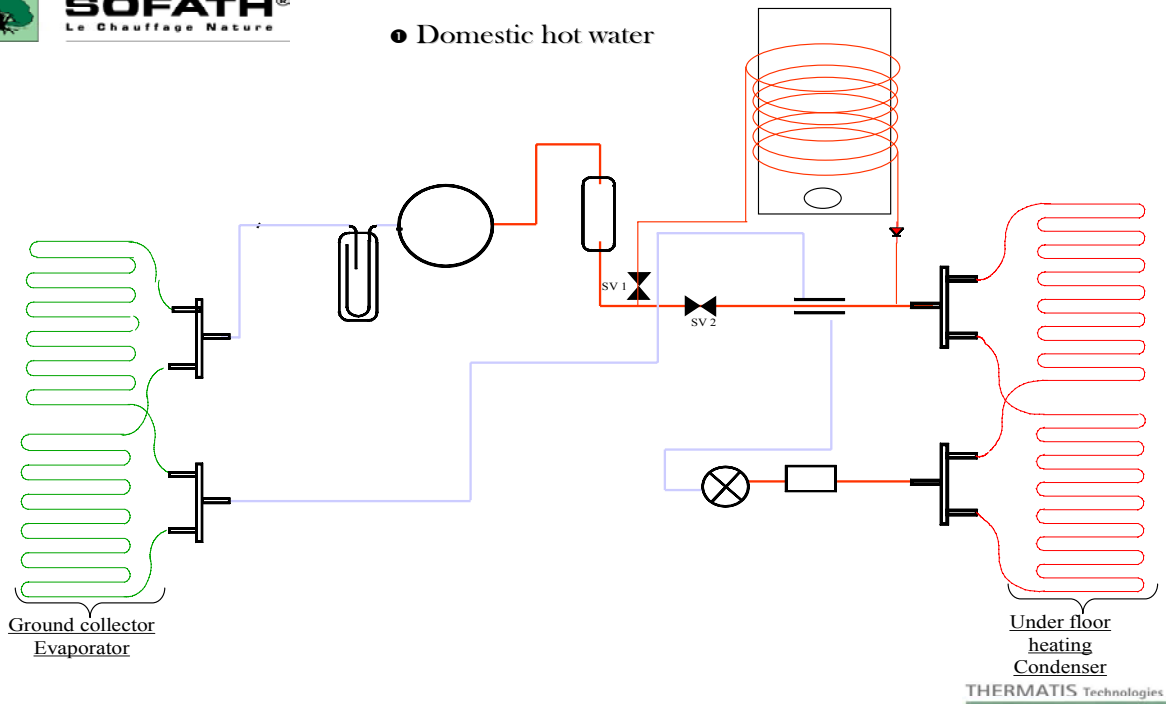

7 REGULATION OF HEATING ZONES

To obtain a comfortable temperature regulation of different heating zones a couple of possibilities is available.

For example, 2 pilot thermostats and / or set back thermostats can be used. (on request)

8 SWIMMINGPOOL (*optional*)

The *Natea* range can be equipped with a special heat exchanger that can heat the pool water. It is possible to heat the home and the swimming pool simultaneously, with priority given to heating the home (when the home heating is activated, the swimming pool heating is de-activated).

9 COOLING (*optional*)

The *Natea* range can be equipped with the option of a change over valve. This cools the interior living environment only with fan coil units. There are different types of fan coil units (breast panel, ceiling or ducted) providing the perfect solution for every home layout.



EXAMPLE OF A COMPONENT DIAGRAM

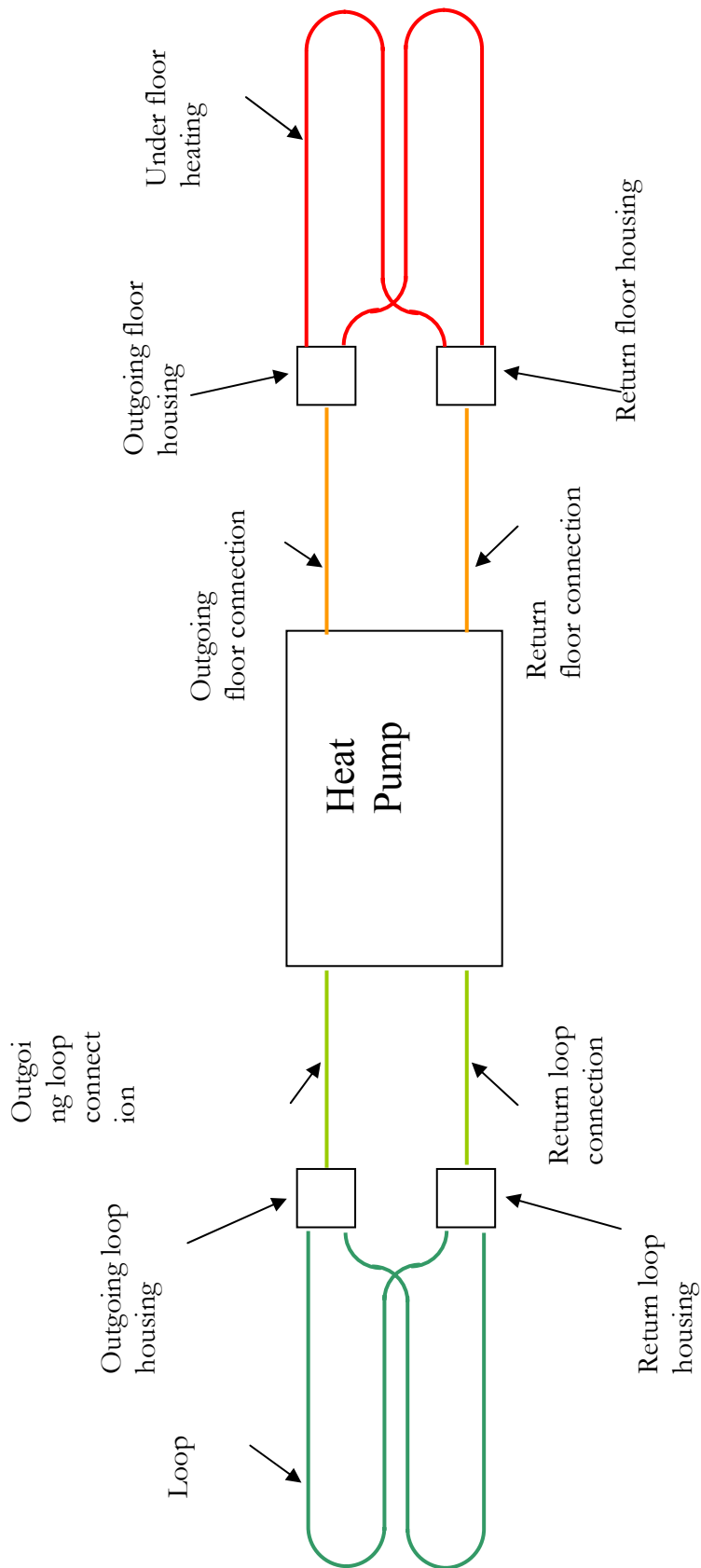

Non-binding schematic diagram shown only as an indication